

# An Efficient Algorithm For Transient and Distortion Analysis of Mildly Nonlinear Analog Circuits

Junjie Yang

Department of Electrical Engineering  
University of California, Riverside, CA 92521, USA  
jyang@ee.ucr.edu

Sheldon X.-D. Tan

Department of Electrical Engineering  
University of California, Riverside, CA 92521, USA  
stan@ee.ucr.edu

**Abstract**— *This paper presents an effective approach to transient and distortion analyses for mildly nonlinear analog circuits. Our method is based on Volterra functional series representation of nonlinear circuits. It computes the nonlinear responses using nonlinear current method which recursively solves a series of linear Volterra circuits to obtain linear and higher-order responses of a nonlinear circuit. The linear Volterra circuits are solved in frequency domain using an efficient graph-based technique, which can derive transfer functions of any large linear network very efficiently. The harmonic distortion can be directly obtained in the frequency domain while the transient responses are obtained via inverse Laplace transformation. The new algorithm takes advantage of the identical Volterra circuits for second and higher order response, which results in significant saving in deriving the transfer functions. Experimental results for a number of nonlinear circuits are obtained and compared with SPICE3 to validate the effectiveness of this method.*

## I. INTRODUCTION

Transient analysis of nonlinear circuits is the most computationally intensive analysis. Linear multistep formulas (LMS) based on backward difference formulas [1] are widely used methods for transient simulation of nonlinear circuits due to their robustness. The so-called predictor-corrector algorithms where explicit LMS formulas for the predictor and an implicit LMS formula for the corrector can be used to further speed up the transient simulation. These methods are general enough for both wildly and hard nonlinear circuits. Since Newton-Raphson iterations are carried out at every time step of integration, these algorithms are, however, very time consuming. If only steady state response is required, some special analysis methods for nonlinear circuits were developed such as harmonic balance methods in frequency domain and shooting methods in time domain [2].

For wireless/communication applications, a number of circuits which operate at radio frequencies (RF) typically exhibits so-called mildly or weakly nonlinear properties where devices typically have a fixed dc operating point and the inputs are ac signals. When the amplitude of these input signals is small (such that their operation points do not change too much), the nonlinearities in these circuit can be approximated adequately using the truncated Taylor series expansion of the nonlinear devices at their dc operating points [3].

The mildly nonlinearities can be exploited to speed up the transient simulation for such nonlinear circuits [4]. Exam-

ples are linear centric method for nonlinear distortion analysis [5] and sampled-data simulation method using Volterra functional series [6]. Volterra functional series can represent a weakly nonlinear function in terms of a number of linear functions called Volterra kernels. From circuit theory's perspective, it leads to a set of linear circuits, called Volterra circuits, whose responses can adequately approximate the response of the original nonlinear circuit. In [6], a sampled-data simulation method is used where the simulation errors are dependent on sampling intervals and sampling window sizes. As a result, the runtime is dependent on the accuracy requirements. It is also difficult to obtain frequency domain information such as harmonic distortions as the algorithm operates in the time domain.

In this paper, we propose a new approach to transient and distortion analysis of mildly nonlinear analog circuits. Our method is also based on the Volterra functional series. But instead of solving the Volterra circuits in time domain as done by traditional methods like SPICE3 or by the sampled-data method [6], we solve the Volterra circuits in frequency domain by using a graph-based symbolic analysis method [7, 8]. Once frequency domain responses are obtained, transient responses can be obtained by fast numerical inverse Laplace transformation [1]. One important benefit for doing frequency domain analysis is that we can easily obtain the frequency-domain characteristics like harmonic distortions as they can be easily computed from the frequency responses of various order Volterra circuits. Experimental results for some real nonlinear circuits are studied and compared with SPICE3 to validate the new method. Both transient and second harmonic distortion (HD2) results are computed for each nonlinear circuit to show the effectiveness of the new method.

This paper is organized as follows: Section II reviews the concept of the Volterra circuit models for nonlinear circuits and DDD graphs. Section III presents the new simulation algorithm and illustrates the algorithm using a simple nonlinear circuit. Section IV gives the experimental results for a low noise RF amplifier and compares them with that of SPICE3. Section V concludes the paper.

## II. VOLTERRA CIRCUITS AND DDD GRAPHS

### A. Volterra Circuits

A nonlinear circuit in time domain can be expressed by the following differential equations

$$Gv(t) + C \frac{dv(t)}{dt} = Dw(t) + i_{non}(v(t)) \quad (1)$$

Here  $G$  and  $C$  represent, respectively, the conductance and capacitance matrices whose elements are made of the linear devices and first-order terms of the Taylor series expansion of the nonlinear devices.  $D$  is the position vector for input  $w(t)$  and  $i_{non}(v(t))$  represents the second and higher-order currents generated by the nonlinear devices. By substituting Volterra functional series of  $v(t)$  and  $i(t)$  into the equation, we will obtain a set of linear differential equations [4, 6]:

$$\begin{aligned} Gv_1(t) + C \frac{dv_1(t)}{dt} &= Dw(t) \\ Gv_2(t) + C \frac{dv_2(t)}{dt} &= i_2(v_1(t)) \\ Gv_3(t) + C \frac{dv_3(t)}{dt} &= i_3(v_1(t), v_2(t)) \\ &\dots \\ Gv_m(t) + C \frac{dv_m(t)}{dt} &= i_m(v_1(t), v_2(t), \dots, v_{m-1}(t)) \end{aligned} \quad (2)$$

where  $v_m(t)$  is the  $m$ -th order term of Volterra series expansion of  $v(t)$  and  $i_m(t)$  is the input of the  $m$ -th order Volterra circuit and can be obtained from lower-order responses:  $v_{m-1}(t), v_{m-2}(t), \dots, v_1(t)$ .

For a given nonlinear circuit, we assume that currents are nonlinear functions of voltages for nonlinear devices, the  $i$ - $v$  characteristic of the nonlinear device can be expanded at the DC operating point as a Taylor series

$$\begin{aligned} I(V) &= I_0 + i \\ &= f(V_0) + \sum_{n=1}^{\infty} \frac{f^{(n)}(V_0)}{n!} v^n = I_0 + \sum_{n=1}^{\infty} a_n v^n \end{aligned} \quad (3)$$

Here  $I_0$  and  $V_0$  represent the DC current and voltage values over the nonlinear device,  $i$  and  $v$  represent the corresponding small signal voltage and current values respectively. Hence  $i$  can be expressed as a polynomial function of  $v$  with coefficients  $a_i, i = 1 \dots n$ . For Volterra functional series, if the input is changed from  $v(t)$  to  $\lambda v(t)$ , we have [4]:

$$v(t) = \sum_{m=1}^{\infty} v_m(t) \lambda^m, i(t) = \sum_{m=1}^{\infty} i_m(t) \lambda^m \quad (4)$$

Substituting Eq.(3) into Eq.(4), we have

$$\sum_{m=1}^{\infty} i_m(t) \lambda^m = \sum_{n=1}^{\infty} a_n \left( \sum_{m=1}^{\infty} v_m(t) \lambda^m \right)^n. \quad (5)$$

Equating terms of the same order in  $\lambda$ , we have

$$i_m(t) = a_1 v_m(t) + J_m(t), \quad (6)$$

where  $J_m(t)$  is the contribution from the responses of low order (less than  $m$ ) Volterra circuits. But for  $m = 1, J_m(t) = 0$ . Eq.(6) essentially reflects the fact that each Volterra circuit is a linear circuit ( $a_1$  is used for all the Volterra circuits for the nonlinear device) and higher order responses can be computed in an order-increasing way starting from the first order. The response of the whole circuit will be the sum of the responses from all the Volterra circuits.

### B. The DDD Graph based Method for Deriving Transfer Functions

In this subsection, we briefly review a graph-based method, called determinant decision diagrams (DDD), to derive the exact transfer functions of a linear circuit [9].

*Determinant Decision Diagrams* [9] are compact and canonical graph-based representation of determinants. A DDD graph is similar to binary decision diagrams (BDDs) except that a sign is associated with each node to represent the sign of product terms from expansion of determinants. Also like BDDs, DDDs are very capable of representing huge number of symbolic terms from a determinant. Most importantly, it can derive the  $s$ -expanded polynomial of a determinant symbolically via  $s$ -expanded DDDs [7]. The recent hierarchical approach using DDD graphs can essentially derive transfer functions for almost arbitrary large networks [8], which makes the solving of linear networks in frequency domain much easy and efficient.

### III. NEW APPROACH TO TRANSIENT ANALYSIS OF NONLINEAR CIRCUITS

From previous analysis on Volterra functional series, we know that all Volterra circuits are linear circuits similar to the original circuit. All second and higher-order Volterra circuits are the same except the input current sources are different.

As a result, the new method consists of following steps to obtain the transient response and harmonic distortions of a nonlinear circuit: (1) Based on the nonlinear analytical expressions of  $i$ - $v$  curve for each nonlinear device in the nonlinear circuit, derive the corresponding relationship between  $i_m$  and  $v_m$  for each of them and generate the corresponding Volterra circuits; (2) Compute the transfer functions for each Volterra circuit using the DDD-based method. Note that only two linear circuits are required, i.e. the circuit for the first order response and the circuit for the higher order responses. (3) Add all the frequency/transient responses of different-order Volterra circuits to obtain the frequency/transient responses of the original nonlinear circuit. Specific harmonic distortions can be obtained by computing the transfer functions in the Volterra circuits of different orders.

In the following we use a simple nonlinear circuit to demonstrate the new method. The circuit is shown on the top part of Fig. 1 which consists of a nonlinear diode. The devices take the following values:  $R = 20k\Omega, I_s = 1 \times 10^{-6}A, C_0 = 1.0 \times 10^{-12}F$ , where  $I_s$  is the saturation current of the diode. The input is  $V_{in} = 0.7 + 0.1 \sin(2\pi ft)$  at  $f = 1MHz$ . For a diode, we have the following equation characterizing its  $i$ - $v$  relationship:

$$i_D = I_s \left( e^{\frac{v_D}{V_T}} - 1 \right) \quad (7)$$

where  $i_D$  and  $v_D$  are the current and voltage of the diode respectively, and  $V_T$  is the thermal voltage. Let  $i_d$  and  $v_d$  be the AC components of  $i_D$  and  $v_D$ , then we have the following Taylor expansion

$$i_D = I_D \left[ \frac{v_d}{V_T} + \frac{v_d^2}{2V_T^2} + \frac{v_d^3}{6V_T^3} + \frac{v_d^4}{24V_T^4} + \frac{v_d^5}{120V_T^5} + \dots \right] \quad (8)$$

where  $I_D = I_s \left( e^{\frac{V_D}{V_T}} - 1 \right)$ . The simulated DC values are  $V_D = 0.08926V, I_D = 30.385\mu A$ . Replace  $i_d$  and  $v_d$  with its Volterra series, we obtain

$$i_{d,1} = \frac{I_D}{V_T} v_{d,1} \quad (9)$$

$$i_{d,2} = \frac{I_D}{V_T} v_{d,2} + \frac{1}{2V_T^2} v_{d,1}^2 I_D \quad (10)$$

$$i_{d,3} = \frac{I_D}{V_T} v_{d,3} + \left( \frac{1}{2V_T^2} (2v_{d,1}v_{d,2} + \frac{1}{6V_T^3} v_{d,1}^3) \right) I_D \quad (11)$$

$$i_{d,4} = \frac{I_D}{V_T} v_{d,4} + \left( \frac{1}{2V_T^2} (2v_{d,1}v_{d,3} + v_{d,2}^2) + \frac{1}{6V_T^3} (3v_{d,1}^2v_{d,2}) + \frac{1}{24V_T^4} v_{d,1}^4 \right) I_D \quad (12)$$

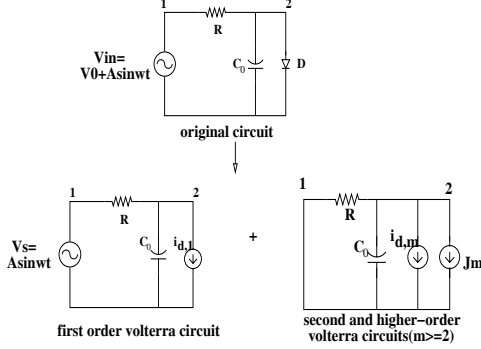

Fig. 1. A simple diode circuit and its Volterra circuits

The Volterra circuits of different orders are shown in Fig. 1. For the first-order Volterra circuit, the voltage transfer function from the input node 1 to the output node 2 is computed by DDD-based method as

$$H_{12}(s) = \frac{V_2(s)}{V_1(s)} = \frac{-5.0 \times 10^{-5}}{0.00123 + 1.0 \times 10^{-12}s} \quad (13)$$

For the second order or higher order Volterra circuits, the impedance driving-point function is computed from node 2 to node 2 as  $J_m(t)$  becomes the new stimulus. As a result, we have

$$H_{22}(s) = \frac{V_2(s)}{J_2(s)} = \frac{1.0}{0.00123 + 1.0 \times 10^{-12}s} \quad (14)$$

After this, we use inverse Laplace transformation to obtain the transient response for each of the Volterra circuits.

$$v_{d,1}(t) = \mathcal{L}^{-1}(V_{in}(s)H_{12}(s))$$

$$J_2(s) = \mathcal{L}\left(\frac{I_D}{2V_T^2} (\mathcal{L}^{-1}(V_{in}(s)H_{12}(s)))^2\right)$$

$$v_{d,2}(t) = \mathcal{L}^{-1}(J_2(s)H_{22}(s))$$

...

$$V_{out}(s) = V_{in}(s)H_{12}(s) + J_2(s)H_{22}(s) + J_3(s)H_{22}(s) + \dots$$

The transient response at node 2 is shown in Fig. 2.

For distortion analysis, let's consider the second harmonic distortion (HD2) since it is the most dominant harmonic distortion in most cases. It is defined as follows:

$$HD2 = 20 \log \left( \frac{|A_{2w_0}|}{|A_{w_0}|} \right), \quad (15)$$

where  $A_{w_0}$  is the amplitude of the input signal and  $A_{2w_0}$  is the second harmonic amplitude at the output node which can be easily computed from the second order Volterra circuit. The computed HD2 is shown in Fig. 3. Similarly, we can obtain HD3, HD4 ... etc.

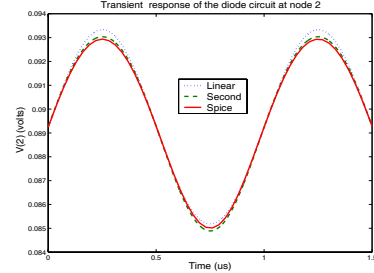

Fig. 2. Transient response for the diode circuit

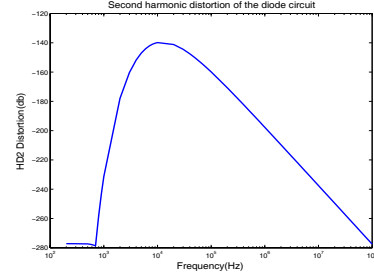

Fig. 3. Second harmonic distortion (HD2) for the diode circuit

#### IV. EXPERIMENTAL RESULTS

The proposed algorithm has been implemented using C++. We simulate a number of nonlinear analog circuits using the new algorithm. The experimental results are collected on a PC with 2.4Ghz P-IV CPU and 484MB memory. But due to the space limitation, we only report the detailed simulation results for one bipolar low-noise amplifier (LNA) shown in Fig. 4 in the following.

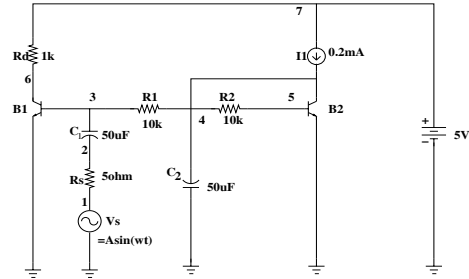

Fig. 4. A simple low-noise amplifier circuit

Firstly, we obtain the DC conditions from SPICE3 for the nonlinear device. We get  $V_B = V(3) = 0.73V$ ,  $V_C = V(6) = 4.8V$ ,  $I_{C1} = 0.19mA$ , and then the AC parameters are computed as follows:  $r_b = 1.0\Omega$ ,  $r_\pi = 13.16k\Omega$ ,  $C_u = 133.8fF$ ,  $C_\pi = 20.66fF$ ,  $g_m = \frac{I_C}{V_T} = 0.0076A/V$ ,  $r_o = 510k\Omega$ . The AC equivalent circuit is shown in Fig. 5 along with the second and higher order Volterra circuits.

By using DDD-based method, we obtain all the required transfer functions

$$H_{14}(s) = \frac{V_4(s)}{V_1(s)} = \frac{0.0015 - 4.16 \times 10^{-15}s}{0.0002 + 4.60 \times 10^{-15}s + 4.58 \times 10^{-27}s^2},$$

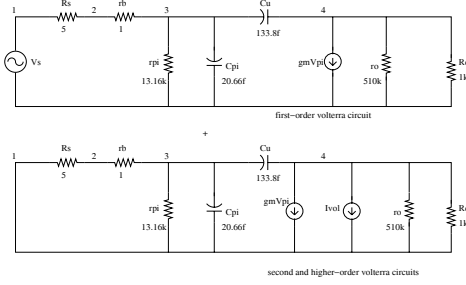

Fig. 5. The Volterra circuits for the low-noise amplifier circuit

$$H_{13}(s) = \frac{V_3(s)}{V_1(s)} = \frac{0.0002 + 4.16 \times 10^{-15}s}{0.0002 + 4.60 \times 10^{-15}s + 4.58 \times 10^{-27}s^2},$$

where  $H_{14}(s)$  and  $H_{13}(s)$  are the transfer functions from input node 1 to output node 4 and node 3 respectively. For the second and higher-order Volterra circuit, we have

$$H_{44}(s) = \frac{V_4(s)}{I_{vol}(s)} = \frac{0.20 + 2.45 \times 10^{-13}s}{0.0002 + 4.60 \times 10^{-15}s + 4.58 \times 10^{-27}s^2},$$

$$H_{43}(s) = \frac{V_3(s)}{I_{vol}(s)} = \frac{-2.496e - 14s}{0.0002 + 4.60 \times 10^{-15}s + 4.58 \times 10^{-27}s^2},$$

where  $H_{44}(s)$  and  $H_{43}(s)$  are the transfer functions from Volterra current source of different orders to output node 4 and node 3 respectively,  $I_{vol}$  is the current source for different order Volterra circuits.

Following the same calculations as shown for the diode circuit, we obtain the transient response shown in Fig. 6. The SPICE3 simulated results are also shown and compared with our results. It can be clearly seen that the results are in good agreement with each other when the second and the third order Volterra circuits are considered. HD2 distortion is also calculated and shown in Fig. 7.

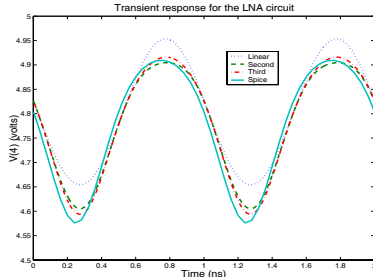

Fig. 6. Transient response for the LNA circuit

The whole computation for deriving transient response takes 1.1 seconds for the new algorithm. While SPICE3 take 2.0 seconds to finish the same task. We notice that if we increase the time interval and number of time steps, SPICE3 simulation time will go up accordingly, while the new method will still take the same time (1.1 seconds) as the new approach computes responses in the frequency domain and is independent of time steps and time intervals. Note that if truncation is carried out for very high order transfer functions, Hurwitz polynomial [10] can be applied to enforce the stability of the transfer functions if stability is required.

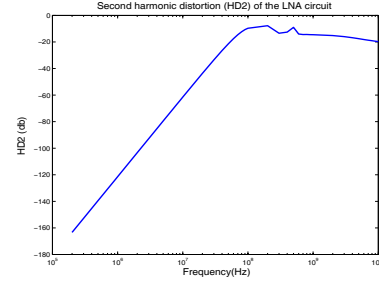

Fig. 7. Second harmonic distortion (HD2) for the LNA circuit

## V. CONCLUSION

In this paper, we have proposed a new approach to transient and distortion analyses of mildly nonlinear analog circuits. The new method is based on Volterra functional series. But instead of solving the Volterra circuits numerically in time domain as traditional methods do, we use a graph-based symbolic method to obtain the responses of Volterra circuits of various orders in frequency domain directly. The new method exploits the identical Volterra circuit structures for higher order nonlinear responses and the efficiency of determinant decision diagrams based method for deriving transfer functions. A number of nonlinear analog circuits have been simulated using the new method and the results have been compared with that of SPICE3 to demonstrate the effectiveness of the proposed method.

## REFERENCES

- [1] J. Vlach and K. Singhal, *Computer Methods for Circuit Analysis and Design*. New York, NY: Van Nostrand Reinhold, 1995.
- [2] K. S. Kundert, J. K. White, and A. Sangiovanni-Vincentelli, *Steady-State Methods for Simulating Analog and Microwave Circuits*. Kluwer Academic Publishers, 1990.
- [3] P. Wambacq and W. Sansen, *Distortion Analysis of Analog Integrated Circuits*. Kluwer Academic Publishers, 1998.
- [4] M. Schetzen, *The Volterra and Wiener Theory of Nonlinear Systems*. New York: Wiley, 1981.
- [5] P. Li and L. Pileggi, "Nonlinear distortion analysis via linear-centric models," in *Proc. Asia South Pacific Design Automation Conf. (ASPDAC)*, pp. 897–903, 2003.
- [6] F. Yuan and A. Opal, "An efficient transient analysis algorithm for mildly nonlinear circuits," *IEEE Trans. on Computer-Aided Design of Integrated Circuits and Systems*, vol. 21, no. 6, pp. 662–673, 2002.
- [7] C.-J. Shi and X.-D. Tan, "Compact representation and efficient generation of s-expanded symbolic network functions for computer-aided analog circuit design," *IEEE Trans. on Computer-Aided Design of Integrated Circuits and Systems*, vol. 20, pp. 813–827, April 2001.
- [8] S. X.-D. Tan, "A general s-domain hierarchical network reduction algorithm," in *Proc. Int. Conf. on Computer Aided Design (ICCAD)*, pp. 650–657, 2003.
- [9] C.-J. Shi and X.-D. Tan, "Canonical symbolic analysis of large analog circuits with determinant decision diagrams," *IEEE Trans. on Computer-Aided Design of Integrated Circuits and Systems*, vol. 19, pp. 1–18, Jan. 2000.
- [10] S. X.-D. Tan and J. Yang, "Hurwitz stable model reduction for non-tree structured RLCK circuits," in *IEEE Int. System-on-Chip Conf. (SOC)*, pp. 239–242, 2003.